

DEPARTMENT OF THE ARMY TECHNICAL BULLETIN

SECURITY OF
TACTICAL WHEELED VEHICLES

Approved for public release; distribution is unlimited.

HEADQUARTERS, DEPARTMENT OF THE ARMY
27 AUGUST 1988

SECURITY OF TACTICAL WHEELED VEHICLES

REPORTING ERRORS AND RECOMMENDING IMPROVEMENTS

You can help improve this bulletin. If you find any mistakes or if you know of a way to improve the procedures, please let us know. Mail your letter or DA Form 2028 (Recommended Changes to Publications and Blank Forms), direct to: Commander, U.S. Army Tank Automotive Command, ATTN: AMSTA-MB, Warren, MI 48397-5000. A reply will be furnished to you.

Approved for public release; distribution is unlimited.

TABLE OF CONTENTS

		PARAGRAPH	PAGE
Section I.	INTRODUCTION		
	Purpose	1-1	1
	Scope	1-2	1
	Installation Level	1-3	1
Section II.	PROCEDURES FOR TACTICAL WHEELED VEHICLES		
	General	2-1	1
	Procedure for M151, M561, M35, M39/M809, M656, M123, M746, and M911	2-2	3
	Procedure for M880	2-3	4
	Mounting Hardware, M880	2-4	5
	Procedure for M1008 Cargo	2-5	6
	Procedure for M1009 Utility	2-6	7
	Procedure for M1010 Ambulance	2-7	8
	Procedure for M915 thru M920	2-8	9
	Procedure for HEMTT	2-9	10
	Procedure for HMMWV	2-10	11

*This Technical Bulletin supersedes TB 9-2300-422-20, 15 February 1980.

Section I. INTRODUCTION

1-1. Purpose.

This bulletin is published to provide security of tactical wheeled vehicles. These instructions are based on requirements established by directive (AR 190-51 Security of Army Property at Unit and Installation Level).

1-2. Scope.

a. This bulletin establishes minimum requirements needed to achieve the protection required for tactical vehicles of all classes.

b. If vehicles are equipped with devices that attain a degree of security equal to that provided by those described in this TB, vehicles need not be modified solely to make them exactly compatible with the devices illustrated.

1-3. Installation Level.

Organizational Maintenance shall perform the installation of security devices described within the bulletin.

Section II. PROCEDURES

2-1. General

a. All vehicles listed (Table 1) will utilize the appropriate clamp to attach the chain to the steering column. Typical clamp is shown (Fig. 1).

Table 1. Recommended Clamps for Listed Vehicles

VEHICLE	CLAMP w/Bolts, Nut, Washer	NSN
M151, 1/4 Ton Trk	MS53041-1	5340-00-756-2403
M561, 1 1/4 Ton Trk	MS53041-2	5340-00-059-5442
M35, 2 1/2 Ton Trk	MS53041-2	5340-00-059-5442
M39/M809, 5 Ton Trk	MS53041-2	5340-00-059-5442
M656, 5 Ton Trk	MS53041-2	5340-00-059-5442
M123, 10 Ton Trk	MS53041-2	5340-00-059-5442
M746 HET	MS53041-2	5340-00-059-5442
M911, 20 Ton Trk	MS53041-3	5340-00-079-8610

b. The following additional hardware requirements apply to all installations.

<u>NOMENCLATURE</u>	<u>PART NUMBER</u>	<u>NSN</u>
CHAIN: Approx 141 Ft (43m), 1/4 in. (6.4mm) Links	RRC-271	4010-00-129-6049
CHAIN: Approx 550 Ft. (167 m), 5/16 in (7.9 mm) Links	RRC-271	4010-00-149-5583
CHAIN: Approx 400 Ft. (122 m), 3/8 in. (9.5 mm) Links	RRC-271	4010-00-184-3476
PADLOCK	MILP17802	5340-00-158-3805

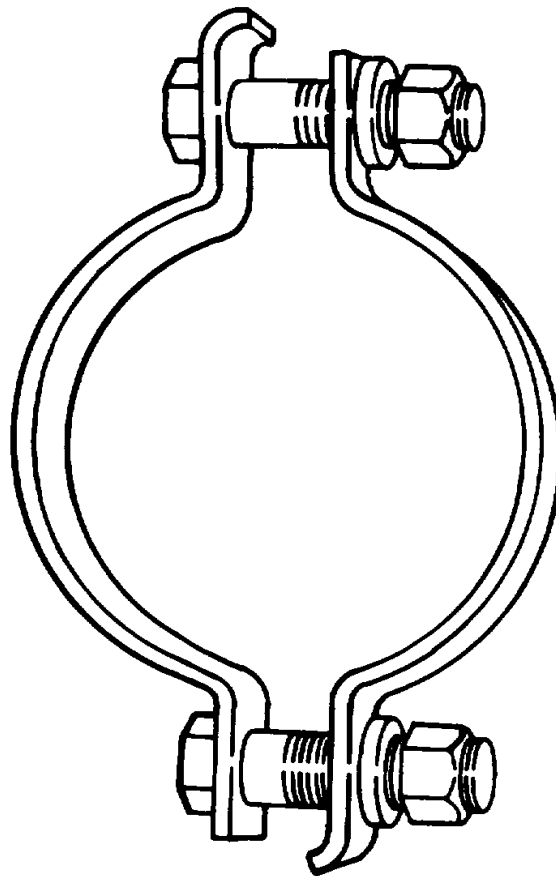

TA 067336

Figure 1. Typical Muffler Clamp.

2-2. Procedures for M151, M561, M35, M39/M809, M656, M123, M746, and M911.

a. A clamp is to be mounted on the steering column (Fig. 2), as clearance will allow. One end of the chain is to be retained by one screw, after which the clamp is to be positioned for maximum operator knee clearance, and tightened securely.

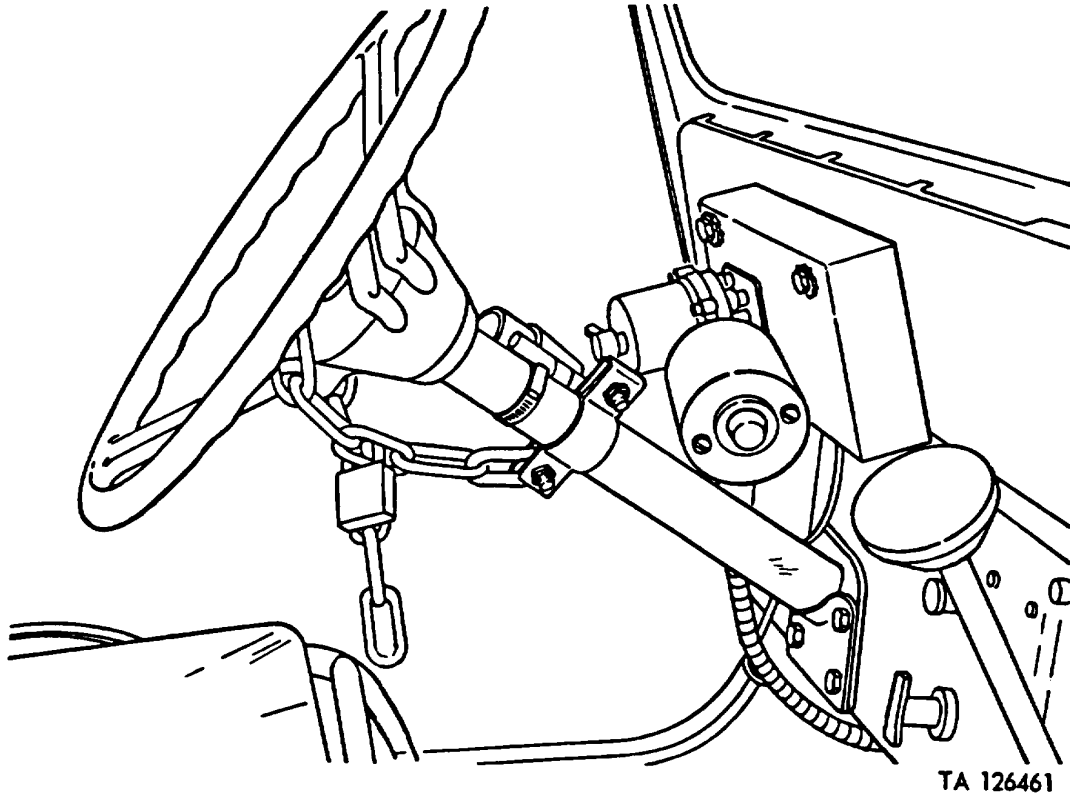

Figure 2. Typical Clamp and Chain, Installed.

CAUTION

Follow all safety precautions when welding. Tack-weld only. Some steering column tubes are only 0.065-inch thick and could be damaged by excessive welding. DO NOT weld adjacent to steering column bushing.

NOTE

Approximately 18 in. (45.7 cm) of chain will be required to reach around steering wheel spokes to secure padlocks.

b. The nuts are to be tack-welded (TM 9-237 Welding Theory and Application) to the screws for a permanent installation. In some cases, the clamp may not have a close fit on the steering column. If this occurs, it is permissible to tack-weld the clamp to the column itself to prevent rotation.

WARNING

**Store chain by winding around column and securing with padlock.
Failure to do so could cause chain to interfere with driver's feet.**

c. When vehicle is in use, chain will be stored by winding the chain around column and securing with padlock. If chain is left unsecured, it could interfere with driver's feet, causing driver to lose control of the vehicle.

d. Steering wheel must be turned all the way to the left or right before securing vehicle with chain or cable.

2-3. Procedure for M880 series, 1 1/4 Ton Truck.**WARNING**

During vehicle operations the chain should be stored beneath the driver's seat, looping chain upon itself, and securing it with a padlock to prevent entanglement with driver's feet. Do not allow additional locks to remain on the security chain, as this may impair proper stowage.

CAUTION

Welding is not allowed on these vehicles due to the potential fire hazard of the seats and floor mats.

a. The design of the steering column on the M880 vehicle will not permit the use of a standard clamp as a chain attachment. The following procedure should be utilized.

b. Attach fixed end of chain with a 3/8 in. (9.5 mm) machinescrew, lockwasher, and nut into manufacturer's hole that is located in the rear of seat riserplate on the operator's side of vehicle. Fasten the chain on the inboard side of riser (Fig. 3). The nut is to be located on the outboard side of riser and, after securing, the screw should be staked to prevent removal.

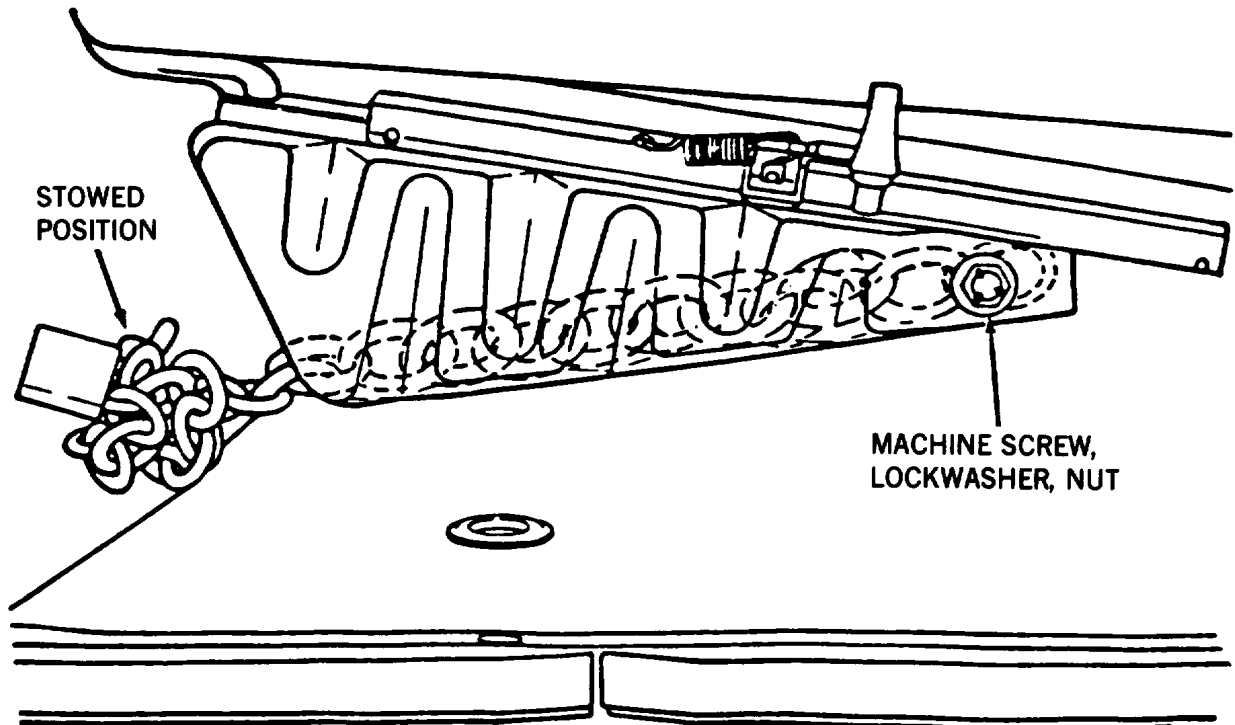

TA 126462

Figure 3. Chain in the Stowed Position.

2-4. Mounting Hardware, M880 Installation only.

<u>NOMENCLATURE</u>	<u>PART NUMBER</u>	<u>NSN</u>
Screw	MS35308-364	5305-00-801-5747
Washer	MS35338-141	5310-00-984-7042
Nut	MS51968-8	5310-00-732-0559

2-5. Procedure for M1008 Cargo.

WARNING

During vehicle operations the chain should be stored beneath the driver's seat, looping chain upon itself, and securing it with a padlock to prevent entanglement with driver's feet. Do not allow additional locks to remain on the security chain, as this may impair proper stowage.

a. Drill a 27/64 inch hole in front end of left hand seat riser bracket. Locate hole 9/16 inch from top of bracket and 5/8 inch from outboard edge of bracket. Insert screw threaded area forward into hole, attach end of chain with washer and nut, then tighten. After tightening, the nut should be staked to prevent removal (Fig. 4). Position chain around steering wheel spokes and secure with padlock.

b. Parts required are as follows:

<u>NOMENCLATURE</u>	<u>QTY</u>	<u>NSN</u>
Screw	1	5305-00-801-5747
Washer	1	5310-00-984-7042
Nut	1	5310-00-732-0559
Chain	30 inch	5340-00-158-3805

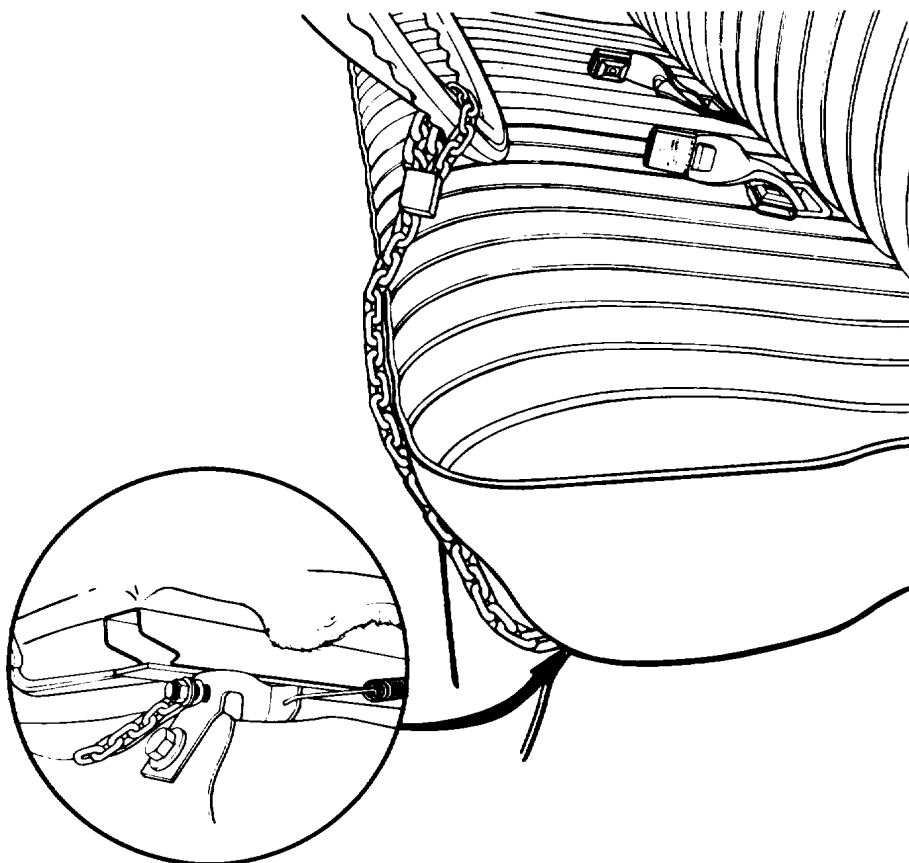

Figure 4. M1008 Cargo Chain Position.

2-6. Procedure for M1009 Utility.

WARNING

During vehicle operations the chain should be stored beneath the driver's seat, looping chain upon itself, and securing it with a padlock to prevent entanglement with driver's feet. Do not allow additional locks to remain on the security chain, as this may impair proper stowage.

a. Drill a 27/64 inch hole in driver's seat forward bracket. Locate hole 1 1/2 inch above cab floor and 1 inch from front edge of bracket. Insert screw in hole with threaded area facing inboard; attach end of chain with washer and nut, then tighten. After tightening, the nut should be staked to prevent removal (Fig. 5). Position chain around steering wheel spokes and secure with padlock.

b. Parts required are as follows

<u>NOMENCLATURE</u>	<u>QTY</u>	<u>NSN</u>
Screw	1	5305-00-801-5747
Washer	1	5310-00-984-7042
Nut	1	5310-00-732-0559
Chain	30 inch	5340-00-158-3805

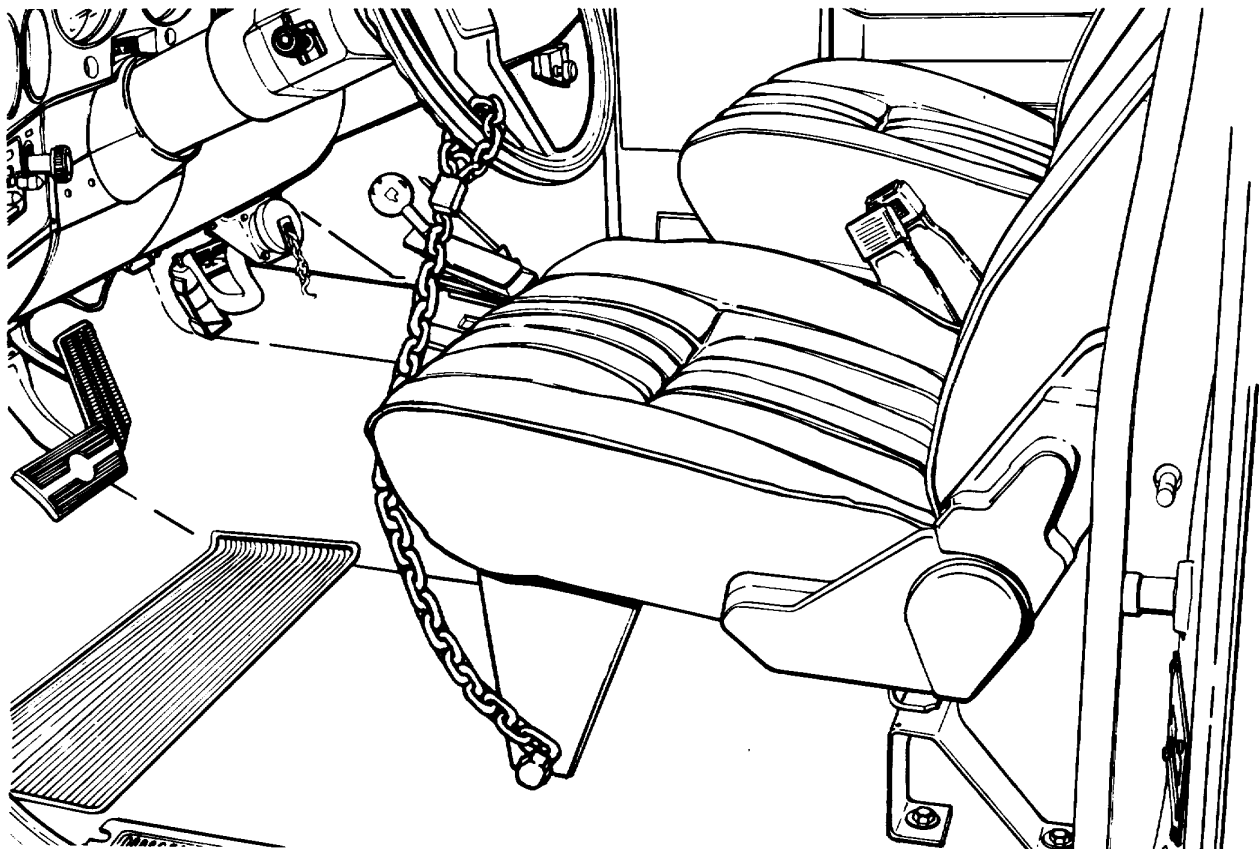

Figure 5. M1009 Utility Chain Position

2-7. Procedure for M1010 Ambulance.

WARNING

During vehicle operations the chain should be stored beneath the driver's seat, looping chain upon itself, and securing it with a padlock to prevent entanglement with driver's feet. Do not allow additional locks to remain on the security chain, as this may impair proper stowage.

- a. Drill a 27/64 inch hole in the forward end of driver's "Right-Hand" seat riser bracket. Locate hole 9/16 inch from the top of bracket and 5/8 inch from the edge of bracket. Insert screw in hole with threaded area facing outboard, attach end of chain with washer and nut, then tighten. After tightening, the nut should be staked to prevent removal (Fig. 6).
- b. Position chain around steering wheel spokes and secure with padlock.
- c. Parts required are as follows:

<u>NOMENCLATURE</u>	<u>QTY</u>	<u>NSN</u>
Screw	1	5305-00-801-5747
Washer	1	5310-00-984-7042
Nut	1	5310-00-732-0559
Chain	30 inch	5340-00-158-3805

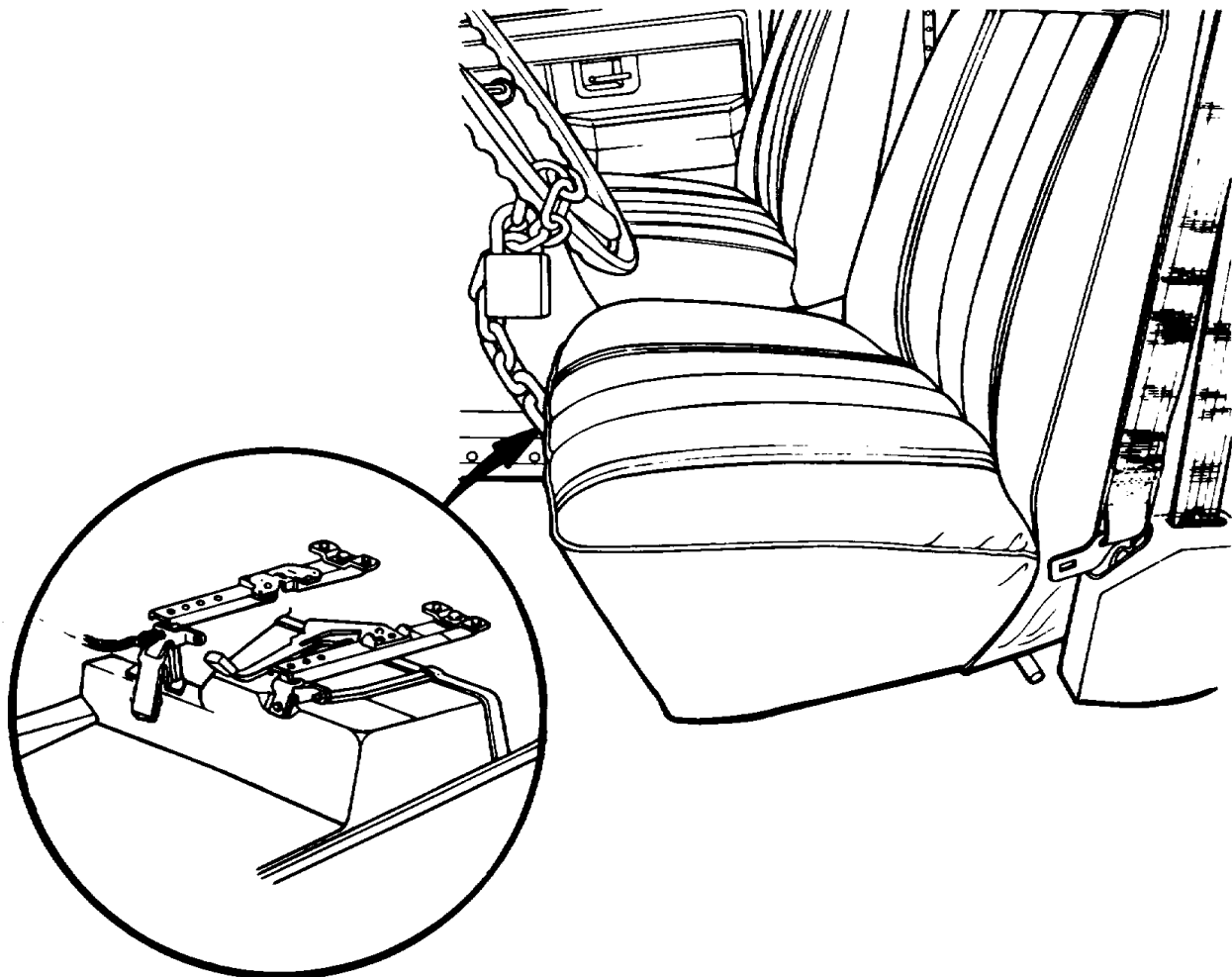

Figure 6. M1010 Ambulance Chain Position.

2-8. Procedures for M915 thru M920, M915A1 22 1/2 Ton Truck, 6x6.

a. Loop one end of chain through a U-bolt. Run hex nuts all the way up the U-bolt to give extra support before installing the U-bolt to the seat assembly. Drill two holes (approximately 1 1/2 inches) from the top of the seat riser (using 1/4 inch drill). Mount U-bolt to seat assembly, tighten nuts and stake threads (on inside side of seat assembly), so U-bolts cannot be removed (Fig. 7).

b. Place free end of chain up through and around steering wheel and secure with padlock.

c. Parts required are as follows:

<u>NOMENCLATURE</u>	<u>QTY</u>	<u>NSN</u>
Chain	30 inch	4010-00-286-5527
U-Bolt	1 ea	5306-00-066-4296
Nuts	4 ea	5310-00-851-2674
Lockwashers	2 ea	5310-00-582-5965
Padlock	1 ea	5340-00-158-3805

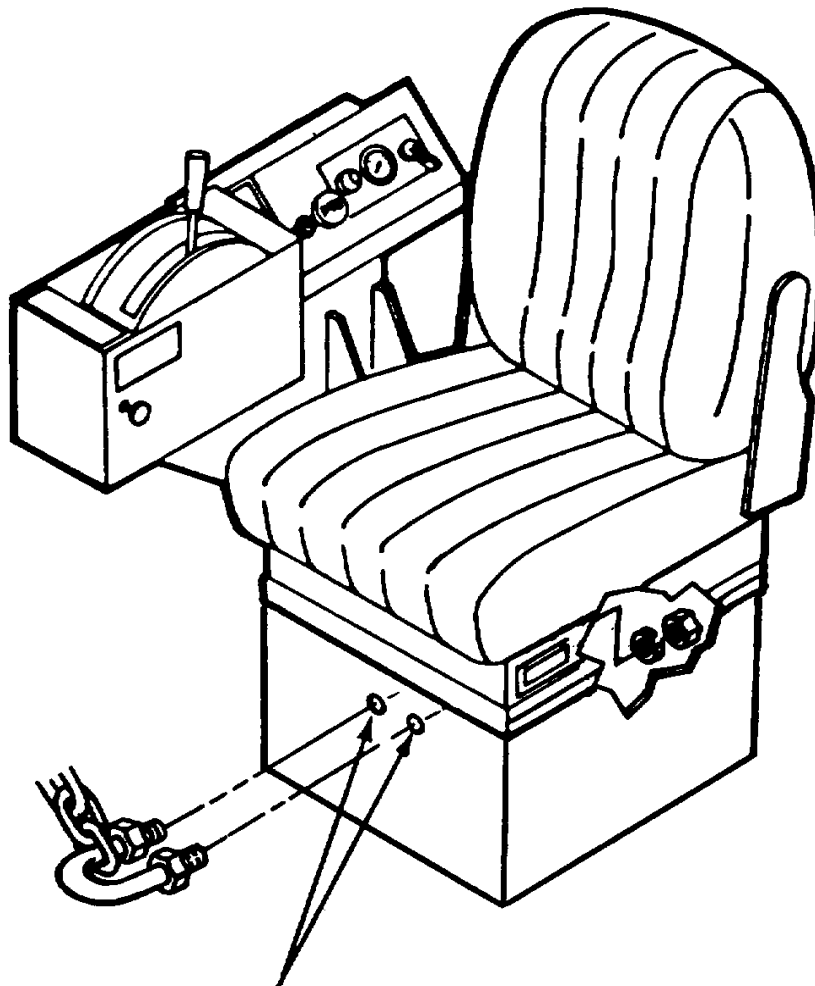

U-bolt attached here

Figure 7. Chain and Attaching Hardware.

2-9. Procedure for HEMTT, M977 Series.

Security locking system is already incorporated into this vehicle. The locking system consists of a bracket with a hole that is attached to the shaft on the 90- degree gear box (Fig. 8); a padlock can be placed in the hole which will limit the steering wheel to be turned 1/4 turn in either direction.

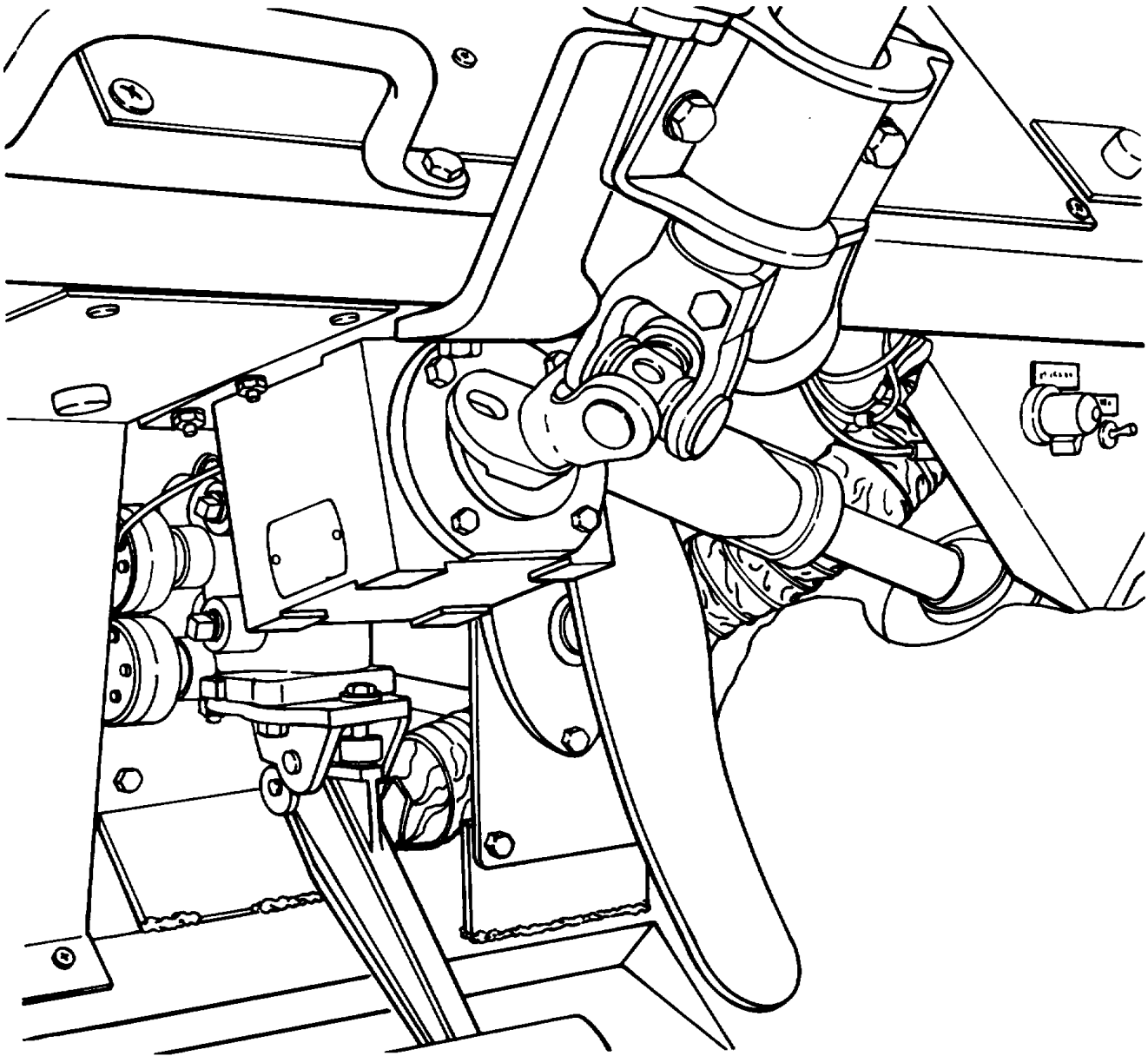

Figure 8. M977 Series Locking System.

2-10. Procedure for HMMWV, M998 Series.

The HMMWV has a steering wheel lock cable (Fig. 9) that permits steering wheel to be locked into position to prevent unauthorized use of vehicle.

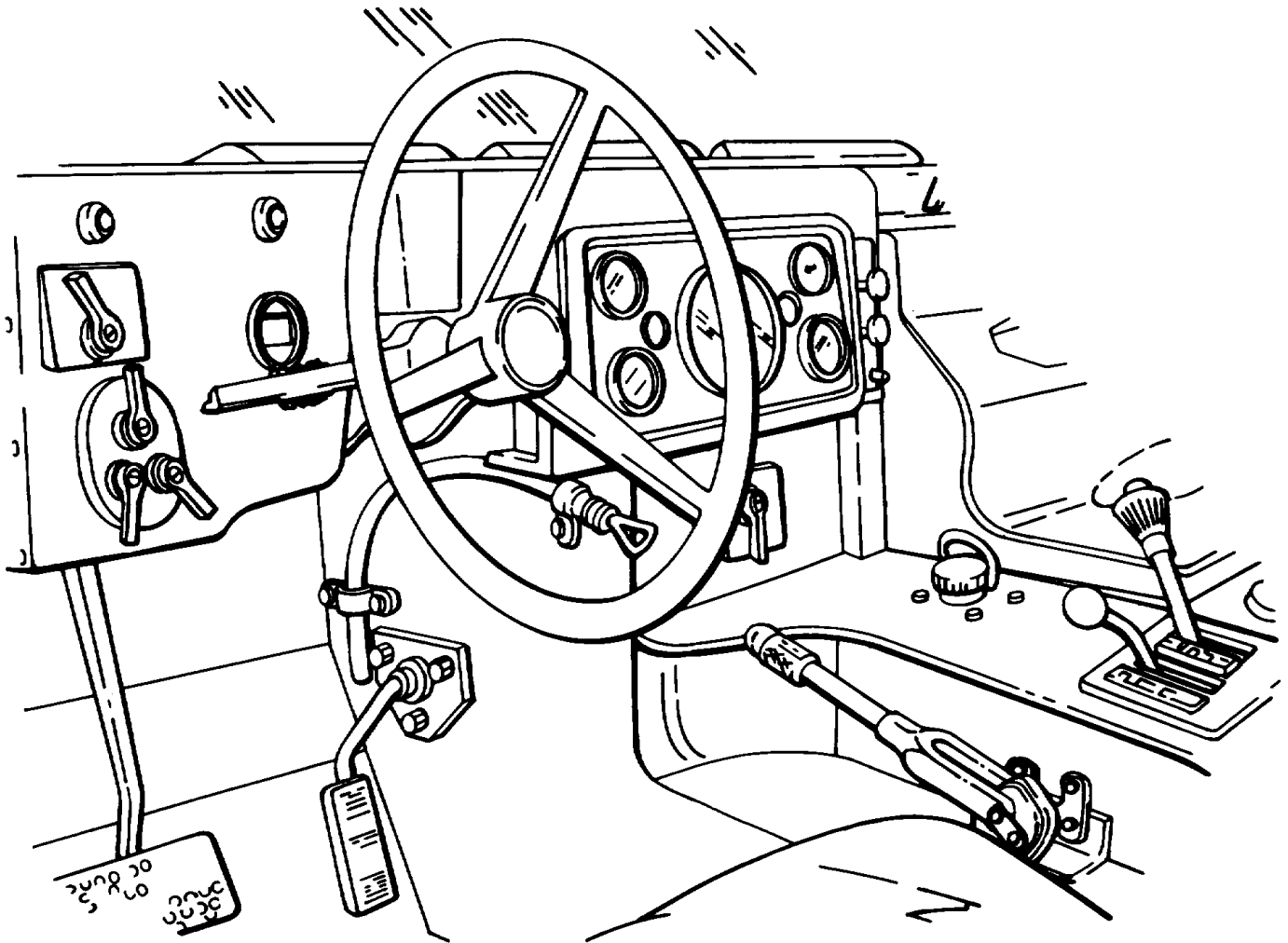

Figure 9. M998 Series Locking System.

By Order of the Secretary of the Army:

CARL E. VUONO
General, United States Army
Chief of Staff

Official:

WILLIAM J. MEEHAN II
Brigadier General United States Army
The Adjutant General

Distribution:

To be distributed in accordance with DA Form 12-38, Unit maintenance requirements for Truck, Commercial Utility Vehicle, Cargo, Tactical, 4x4, M1008, M1008A1, M1009, M1010, M1028, M1029A1, M1031.

☆U.S. GOVERNMENT PRINTING OFFICE: 1996 - 406-421/61230

RECOMMENDED CHANGES TO EQUIPMENT TECHNICAL PUBLICATIONS



SOMETHING WRONG WITH THIS PUBLICATION?

THEN... JOT DOWN THE DOPE ABOUT IT ON THIS FORM, CAREFULLY TEAR IT OUT, FOLD IT AND DROP IT IN THE MAIL!

FROM: (PRINT YOUR UNIT'S COMPLETE ADDRESS)

DATE SENT

PUBLICATION NUMBER

PUBLICATION DATE

PUBLICATION TITLE

BE EXACT... PIN-POINT WHERE IT IS				IN THIS SPACE TELL WHAT IS WRONG AND WHAT SHOULD BE DONE ABOUT IT:
PAGE NO.	PARA-GRAPH	FIGURE NO.	TABLE NO.	

PRINTED NAME, GRADE OR TITLE, AND TELEPHONE NUMBER

SIGN HERE:

TEAR ALONG PERFORATED LINE

DA FORM 2028-2
1 JUL 79

PREVIOUS EDITIONS ARE OBSOLETE.

P.S.—IF YOUR OUTFIT WANTS TO KNOW ABOUT YOUR RECOMMENDATION MAKE A CARBON COPY OF THIS AND GIVE IT TO YOUR HEADQUARTERS.

THE METRIC SYSTEM AND EQUIVALENTS

WEIGHT MEASURE

1 Centimeter = 10 Millimeters = 0.01 Meters = 0.3937 Inches
 1 Meter = 100 Centimeters = 1000 Millimeters = 39.37 Inches
 1 Kilometer = 1000 Meters = 0.621 Miles

WEIGHTS

1 Gram = 0.001 Kilograms = 1000 Milligrams = 0.035 Ounces
 1 Kilogram = 1000 Grams = 2.2 lb.
 1 Metric Ton = 1000 Kilograms = 1 Megagram = 1.1 Short Tons

LIQUID MEASURE

1 Milliliter = 0.001 Liters = 0.0338 Fluid Ounces
 1 Liter = 1000 Milliliters = 33.82 Fluid Ounces

SQUARE MEASURE

1 Sq. Centimeter = 100 Sq. Millimeters = 0.155 Sq. Inches
 1 Sq. Meter = 10,000 Sq. Centimeters = 10.76 Sq. Feet
 1 Sq. Kilometer = 1,000,000 Sq. Meters = 0.386 Sq. Miles

CUBIC MEASURE

1 Cu. Centimeter = 1000 Cu. Millimeters = 0.06 Cu. Inches
 1 Cu. Meter = 1,000,000 Cu. Centimeters = 35.31 Cu. Feet

TEMPERATURE

$5/9(^{\circ}\text{F} - 32) = ^{\circ}\text{C}$
 212° Fahrenheit is equivalent to 100° Celsius
 90° Fahrenheit is equivalent to 32.2° Celsius
 32° Fahrenheit is equivalent to 0° Celsius
 $9/5^{\circ}\text{C} + 32 = ^{\circ}\text{F}$

APPROXIMATE CONVERSION FACTORS

TO CHANGE	TO	MULTIPLY BY
Inches	Centimeters	2.540
Feet	Meters	0.305
Yards	Meters	0.914
Miles	Kilometers	1.609
Square Inches	Square Centimeters	6.451
Square Feet	Square Meters	0.093
Square Yards	Square Meters	0.836
Square Miles	Square Kilometers	2.590
Acres	Square Hectometers	0.405
Cubic Feet	Cubic Meters	0.028
Cubic Yards	Cubic Meters	0.765
Fluid Ounces	Milliliters	29.573
its	Liters	0.473
arts	Liters	0.946
allons	Liters	3.785
Ounces	Grams	28.349
Pounds	Kilograms	0.454
Short Tons	Metric Tons	0.907
Pound-Feet	Newton-Meters	1.356
Pounds per Square Inch	Kilopascals	6.895
Miles per Gallon	Kilometers per Liter	0.425
Miles per Hour	Kilometers per Hour	1.609

TO CHANGE	TO	MULTIPLY BY
Centimeters	Inches	0.394
Meters	Feet	3.280
Meters	Yards	1.094
Kilometers	Miles	0.621
Square Centimeters	Square Inches	0.155
Square Meters	Square Feet	10.764
Square Meters	Square Yards	1.196
Square Kilometers	Square Miles	0.386
Square Hectometers	Acres	2.471
Cubic Meters	Cubic Feet	35.315
Cubic Meters	Cubic Yards	1.308
Milliliters	Fluid Ounces	0.034
Liters	Pints	2.113
Liters	Quarts	1.057
ers	Gallons	0.264
ms	Ounces	0.035
ograms	Pounds	2.205
Metric Tons	Short Tons	1.102
Newton-Meters	Pounds-Feet	0.738
Kilopascals	Pounds per Square Inch	0.145
ometers per Liter	Miles per Gallon	2.354
ometers per Hour	Miles per Hour	0.621

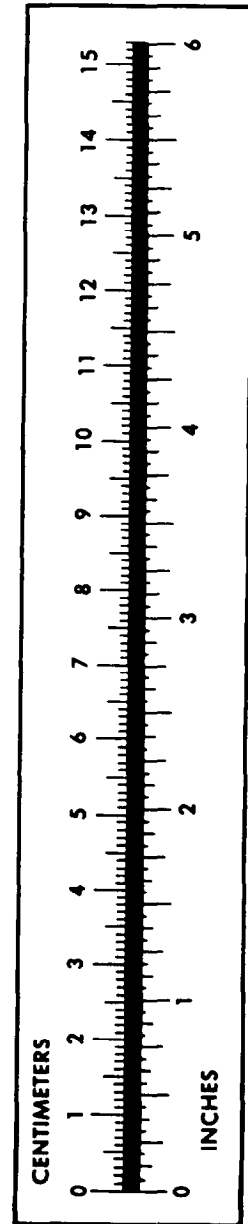

PIN: 033212-000