

TECHNICAL MANUAL

DIRECT SUPPORT AND GENERAL SUPPORT MAINTENANCE REPAIR
PARTS
AND SPECIAL TOOLS LISTS
(INCLUDING DEPOT MAINTENANCE REPAIR
PARTS AND SPECIAL TOOLS)

GENERATOR, ENGINE ACCESSORY
(ALTERNATING CURRENT)

PRESTOLITE MODEL AMA-5102UT
(FSN 2920-909-2483)

LEECE-NEVILLE MODELS 3002AC AND 3002AD
(FSN 2920-909-2483)

5504AA AND 5504AB (FSN 2920-475-1446)

2184AC (FSN 2920-782-1955)

5300GP (FSN 2920-818-8635)

HEADQUARTERS, DEPARTMENT OF THE ARMY

JULY 1974

**TECHNICAL MANUAL }
No. 9-2920-225-34P }**

**HEADQUARTERS
DEPARTMENT OF THE ARMY
WASHINGTON, DC, 22 July 1974**

**Direct Support and General Support Maintenance
Repair Parts and Special Tools Lists
(Including Depot Maintenance Repair
Parts and Special Tools)
GENERATOR, ENGINE ACCESSORY
(ALTERNATING CURRENT)
PRESTOLITE MODEL AMA-5102UT
(FSN 2920-909-2483)
LEECE-NEVILLE MODELS 3002AC and 3002AD
(FSN 2920-909-2483)
5504AA and 5504AB (FSN 2920-475-1446)
2184AC (FSN 2920-782-1955)
5300GP (FSN 2920-818-8635)**

Current as of April 1974

	Page	Fig. No.
Section I. INTRODUCTION	2	
Section II. REPAIR PARTS LIST DIRECT AND GENERAL SUPPORT MAINTENANCE (INCLUDING DEPOT MAINTENANCE REPAIR PARTS AND SPECIAL TOOLS)	10	
GROUP 06— ELECTRICAL SYSTEM	Page	Fig. No.
0601 — GENERATOR		
Generator, Model AMA-5102UT.....	5	1
Generator, Model 3002AC	6	2
Generator, Model 3002AD	7	3
Generator, Model 5504AA, 5504AB and 5300GP	8	4
Generator, Model 2184AC	9	5
Section III. FEDERAL STOCK NUMBER AND PART NUMBER INDEX	12	

***This manual supersedes TM 9-2920-225-34P, 4 February 1972.**

Section I. INTRODUCTION

1. **Scope.** This manual lists repair parts required for the performance of direct and general support maintenance (including depot maintenance Repair Parts and Special Tools) of the Generators, Engine Accessory, FSN 2920-909-2483, 2920-475-1446, 2920-782-1955, and 2920-818-8635.

2. **General.** This repair parts list is divided into the following sections:

a. *Repair Parts List - Section II.* A list of repair parts authorized at the direct and general support (including depot maintenance Repair Parts and Special Tools) levels for the performance of maintenance. The list also includes parts which must be removed for the replacement of the authorized parts. Parts lists are composed of functional groups in ascending numerical sequence, with parts in each group listed in figure and item number sequence.

b. *Federal Stock Number and Part Number Index -Section III.* A list, in ascending numerical sequence, of all Federal stock numbers appearing in the listings, followed by a list, in alphanumeric sequence, of all part numbers appearing in the listings. Federal stock number and part numbers are cross-referenced to each illustration figure and item number appearance.

3. **Explanation of Columns** The following provides an explanation of columns found in the tabular listings:

a. *Illustration.* This column is divided as follows:

(1) *Figure Number.* Indicates the figure number of the illustration in which the item is shown.

(2) *Item Number.* The number used to identify each item called out in the illustration.

b. *Source, Maintenance, and Recoverability Codes (SMR).*

(1) **Source Code.** Source codes are assigned to support items to indicate the manner of acquiring support items for maintenance, repair, or overhaul of end items. Source codes are entered in the first and second positions of the Uniform SMR Code format as follows:

Code	Definition
PA	Item procured and stocked for anticipated or known usage.
PB	Item procured and stocked for insurance purposes because essentiality dictates that a minimum quantity be available in the supply systems.
PC	Item procured and stocked and which otherwise would be coded PA except that it is deteriorative in nature.
PD	Support item, excluding support equipment, procured for

Code	Definition
	initial issue or outfitting and stocked only for subsequent or additional initial issues or outfitting. Not subject to automatic replenishment.
PE	Support equipment procured and stocked for initial issue or outfitting to specified maintenance repair activities.
PF	Support equipment which will not be stocked but which will be centrally procured on demand.
PG	Item procured and stocked to provide for sustained support for the life of the equipment. It is applied to an item peculiar to the equipment which because of probable discontinuance or shutdown of production facilities would prove uneconomical to reproduce at a later time.
KD	An item of depot overhaul/repair kit and not purchased separately. Depot kit defined as a kit that provides items required at the time of overhaul or repair.
KF	An item of a maintenance kit and not purchased separately. Maintenance kit defined as a kit that provides an item that can be replaced at organizational or intermediate levels of maintenance.
KB	Item included in both a depot overhaul/repair kit and a maintenance kit.
MO	Item to be manufactured or fabricated at organizational level.
MF	Item to be manufactured or fabricated at the direct support maintenance level.
MH	Item to be manufactured or fabricated at the general support maintenance level.
MD	Item to be manufactured or fabricated at the depot maintenance level.
AO	Item to be assembled at organizational level.
AF	Item to be assembled at direct support maintenance level.
AH	Item to be assembled at general support maintenance level.
AD	Item to be assembled at depot maintenance level.
XA	Item is not procured or stocked because the requirements for the item will result in the replacement of the next higher assembly.
XB	Item is not procured or stocked. If not available through salvage, requisition.
XB	Installation drawing, diagram, instruction sheet or field service drawing that is identified by manufacturer's part number.
XD	A low mortality item that is not stocked. When required, items will be requested and provided through normal supply channels

NOTE

Cannibalization or salvage maybe used as a source of supply for any items source coded above except those coded XA, XD, and aircraft support items as restricted by AR 700-42.

(2) **Maintenance Code.** Maintenance codes are assigned to indicate the levels of maintenance authorized to USE and REPAIR support items. The maintenance codes are entered in the third and

fourth positions of the Uniform SMR Code format as follows:

(a) The maintenance code entered in the third position will indicate the lowest maintenance level authorized to remove, replace, and use the support item. The maintenance code entered in the third position will indicate one of the following levels of maintenance:

<i>Code</i>	<i>Application/Explanation</i>
C	Crew or operator maintenance performed within organizational maintenance.
O	Support item is removed, replaced at the organizational level.
F	Support item is removed, replaced, used at the direct support level.
H	Support item is removed, replaced, used at the general support level.
D	Support items that are removed, replaced, used at depot, mobil depot, specialized repair activity only.

(b) The maintenance code entered in the fourth position indicates whether the item is to be repaired and identifies the lowest maintenance level with the capability to perform complete repair (i.e., all authorized maintenance functions). This position will contain one of the following maintenance codes:

<i>Code</i>	<i>Application/Explanation</i>
O	The lowest maintenance level capable of complete repair the support item is the organizational level.
F	The lowest maintenance level capable of complete repair of the support item is the direct support level.
H	The lowest maintenance level capable of complete repair of the support item is the general support level.
D	The lowest maintenance level capable of complete repair of the support item is the depot level, performed by (enter applicable activity) depot, mobile depot or specialized repair activity.
L	Repair restricted to designated Specialized Repair Activity.
Z	Non-reparable. No repair is authorized.
B	No repair is authorized. The item maybe reconditioned by adjusting, lubricating, etc., at the user level. No parts or special tools are procured for the maintenance of this item.

(3) Recoverability Code. Recoverability codes are assigned to support items to indicate the disposition action on unserviceable items. The recoverability code is entered in the fifth position of the Uniform SMR Code format as follows:

<i>Recoverability Code</i>	<i>Definition</i>
Z	Nonreparable item. When unserviceable, condemn and dispose at the level indicated in position 3.
O	Reparable item. When uneconomically reparable, condemn and dispose at organizational level.
F	Reparable item. When uneconomically reparable, condemn and dispose at the direct support level.
H	Reparable item. When uneconomically reparable, condemn and dispose at the general support level.
D	Reparable item.. When beyond lower level repair capability, return to depot. Condemnation and disposal not authorized below depot level.

Recoverability

Definition

- L Reparable item. Repair, condemnation and disposal not authorized below depot/specialized repair activity level
- A Item requires special handling or condemnation procedures because of specific reasons (i.e., precious metal content high dollar value, critical material or hazardous material). Refer to appropriate manuals/directives for specific instructions

c. *Federal Stock Number.* Indicates the Federal stock number assigned to the item and will be used for requisitioning purposes.

NOTE

Federal stock numbers that are missing for P source-coded items are not currently recorded in the AMDF. When these stock numbers are broadcast in the AMDF, they will be provided by a change to this manual.

d. *Part Number.* Indicates the primary number used by the manufacturer (individual, company, firm, corporation, or Government activity), which controls the design and characteristics of the item by means of its engineering drawings, specifications standards, and inspection requirements, to identify an item or range of items.

e. *Federal Supply Code for Manufacturer (FSCM).* The FSCM is a 5-digit numeric code listed in SB 708-42 which is used to identify the manufacturer, distributor, or Government agency, etc.

f. *Description.* Indicates the Federal item name and, if required, a minimum description to identify the item.

g. *Unit of Measure (UIM).* Indicates the standard of the basic quantity of the listed item as used in performing the actual maintenance function. This measure is expressed by a two-character alphabetical abbreviation (e.g., ea, in, pr, etc). When the unit of measure differs from the unit of issue, the lowest unit of issue that will satisfy the required units of measure will be requisitioned.

h. *Quantity Incorporated in Unit.* Indicates the quantity of the item used in the breakout shown on the illustration figure, which is prepared for a functional group, subfunctional group, or an assembly. A "V" appearing in this column in lieu of a quantity indicates that no specific quantity is applicable, (e.g., shims, spacers, etc).

4. Special Information.

a. Usable on codes are shown in the description column. Identification of the usable on codes used in this publication are:

<i>Code</i>	<i>Used on</i>
A	Prestolite Model AMA-5102UT
B	Leece-Neville Model 3002AC
C	Leece-Neville Model 3002AD
D	Leece-Neville Model 5504AA
E	Leece-Neville Model 5504AB

TM 9-2920-225-34P

Code	Used on
F	Leece-Neville 5300GP
G	Leece-Neville Model 2184AC

b. End Item Application.

Carrier, Cargo, Amphibious, Tracked, M116	(TM 9-2320-223)
Carrier, Cargo, Tracked, 6-Ton, M548	(TM 9-2320-247)
Carrier, Command and Reconnaissance Armored, M114	TM 9-2320-224)
Carrier, Command Post, Light, Tracked, M577	(TM 9-2300-224)
Carrier, Command Post, Light, Tracked, M577A1	(TM 9-2300-257)
Carrier, Flame Thrower, Self-Propelled, M132	(TM 9-2300-224)
Carrier, Flame Thrower, Self-Propelled, M132A1	(TM 9-2300-257)
Carrier, Guided Missile Equipment, Self-Propelled, XM727	(TM 9-1450-501)
Carrier, Guided Missile Equipment, XM730	(TM 9-1450-585)
Carrier, Mortar, 81-mm, Self-Propelled, M125A1	(TM 9-2300-257)
Carrier, Mortar, 107-mm, Self-Propelled, M106	(TM 9-2300-224)
Carrier, Mortar, 107-mm, Self-Propelled, M106A1	(TM 9-2300-257)
Carrier, Personnel, Full Tracked, Armored, M113	(TM 9-2300-224)
Carrier, Personnel, Full Tracked, Armored, M113A1	(TM 9-2300-257)
Chassis, Gun, Anti-Aircraft Artillery, 20-mm, Self-Propelled, (XM163 Weapons System) XM741)	(TM 9-2300-257)
Howitzer, Light, Self-Propelled, 105-mm, M108 T195E1)	(TM 9-2350-217)
Howitzer, Medium, Self-Propelled, 155-mm, M109 (T196E1)	(TM 9-2350-217)
Rifle, Self-Propelled, Full Tracked, Multi-106-mm, M50A1.	(TM 9-2350-212)
Truck, Utility, 1/4 Ton, 4x4, M38	(TM 9-8014)
Truck, Utility, 1/4 Ton, 4x4, M38A1 and M170	(TM 9-2320-208)
Truck, Utility, 1/4 Ton, 4x4, M151	(TM 9-2320-218)
Truck 3/4 Ton (Family), 4x4	(TM 9-2320-212)
Truck, 2-1/2 Ton Family, 6x6, GMC	(TM 9-8024)
Truck, 2-1/2 Ton (Family), 6x6, REO	(TM 9-2320-209)
Truck, 5 Ton (Family), 6x6	(TM 9-2320-211)

c. Repair parts kits (appear as the *last entries in the repair parts listing for the figure in which its parts are listed as repair parts*).

5. How to Locate Repair Parts

a. When Federal stock number or reference number is unknown:

(1) *First.* Using the table of contents determine the generator model number within which the repair part belongs, i.e. (Model 3002AC) This is necessary since the illustrations are prepared for different generator model numbers, and listings are divided into the same illustration numbers.

(2) *Second.* Find the illustration covering the model number to which the repair part belongs.

(3) *Third.* Identify the repair part on the illustration and note the illustration figure and item number of the repair part.

(4) *Fourth.* Using the repair parts listing, find the illustration figure and item number noted on the illustration.

b. When Federal stock number or reference

number is known.

(1) *First.* Using the *Index of Federal Stock Numbers and Reference Numbers*, find the pertinent Federal stock number or reference number. This index is in ascending FSN sequence followed by a list of reference numbers in ascending alphanumeric sequence, cross-referenced to the illustration figure number and item number.

(2) *Second* Using the repair parts listing, find the illustration for the model number of the repair part and the illustration figure number referenced in the *Index of Federal Number and Reference Numbers*.

6. Recommendations for Maintenance Publications Improvements. You can help to improve this manual by calling attention to errors and by recommending improvements. Your letter or DA Form 2028 (Recommended Changes to Publications and Blank Forms) should be mailed direct to Commander, US Army Tank-Automotive Command, ATTN: AMSTA-MAP, Warren, MI 48090. A reply will be furnished direct to you.

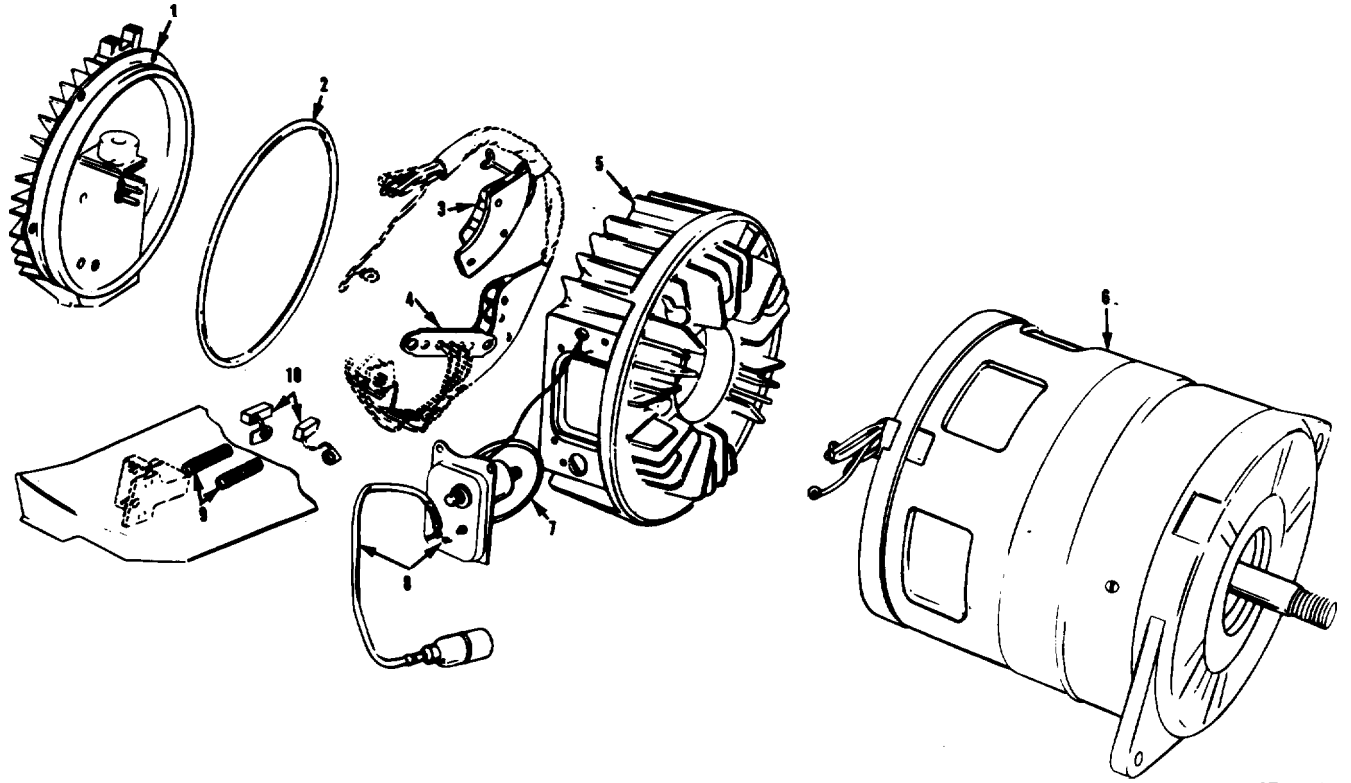

AT 41696

Figure 1. Generator, Model AMA 5102UT

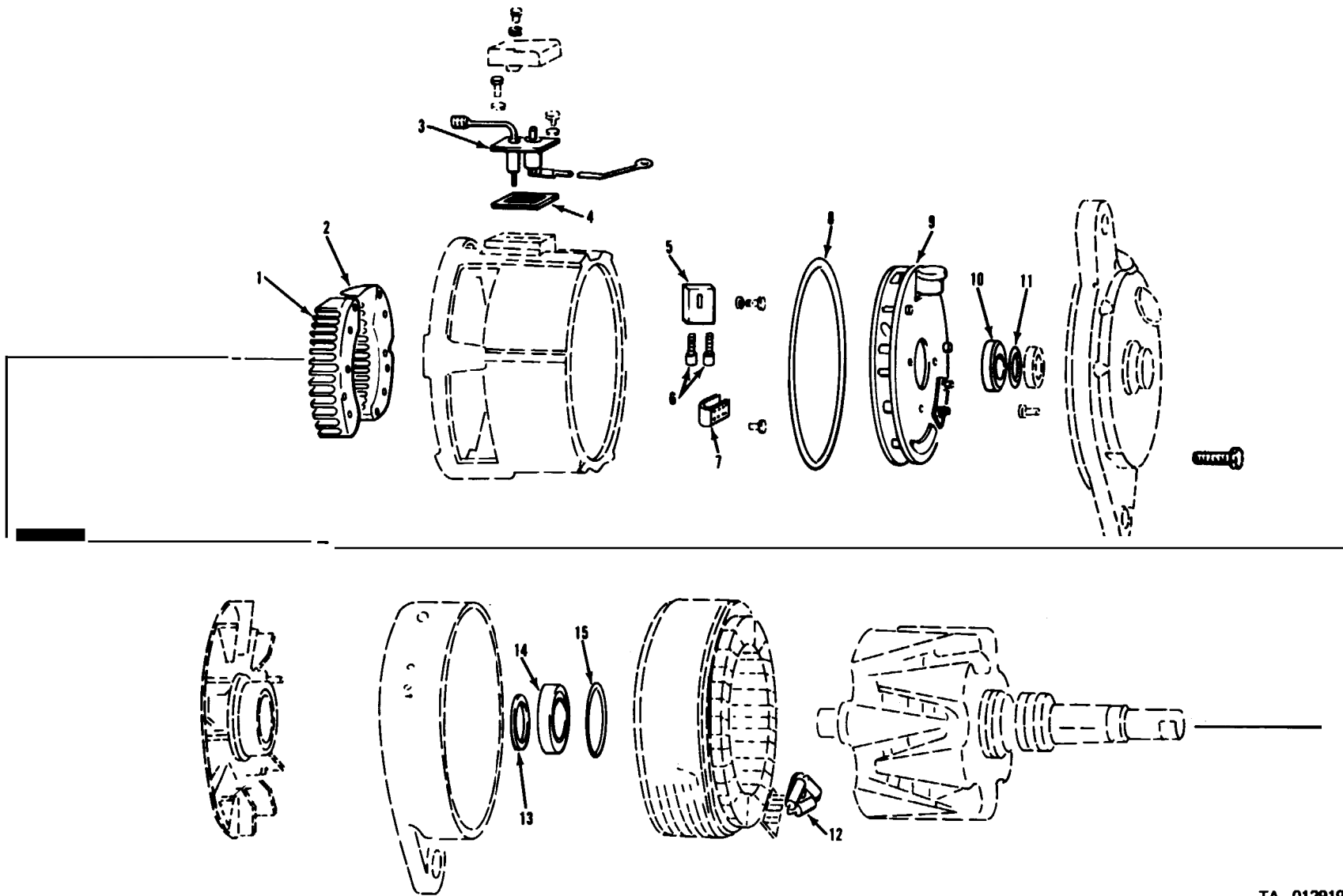

TA 012919

Figure 2. Generator, Model 3002AC

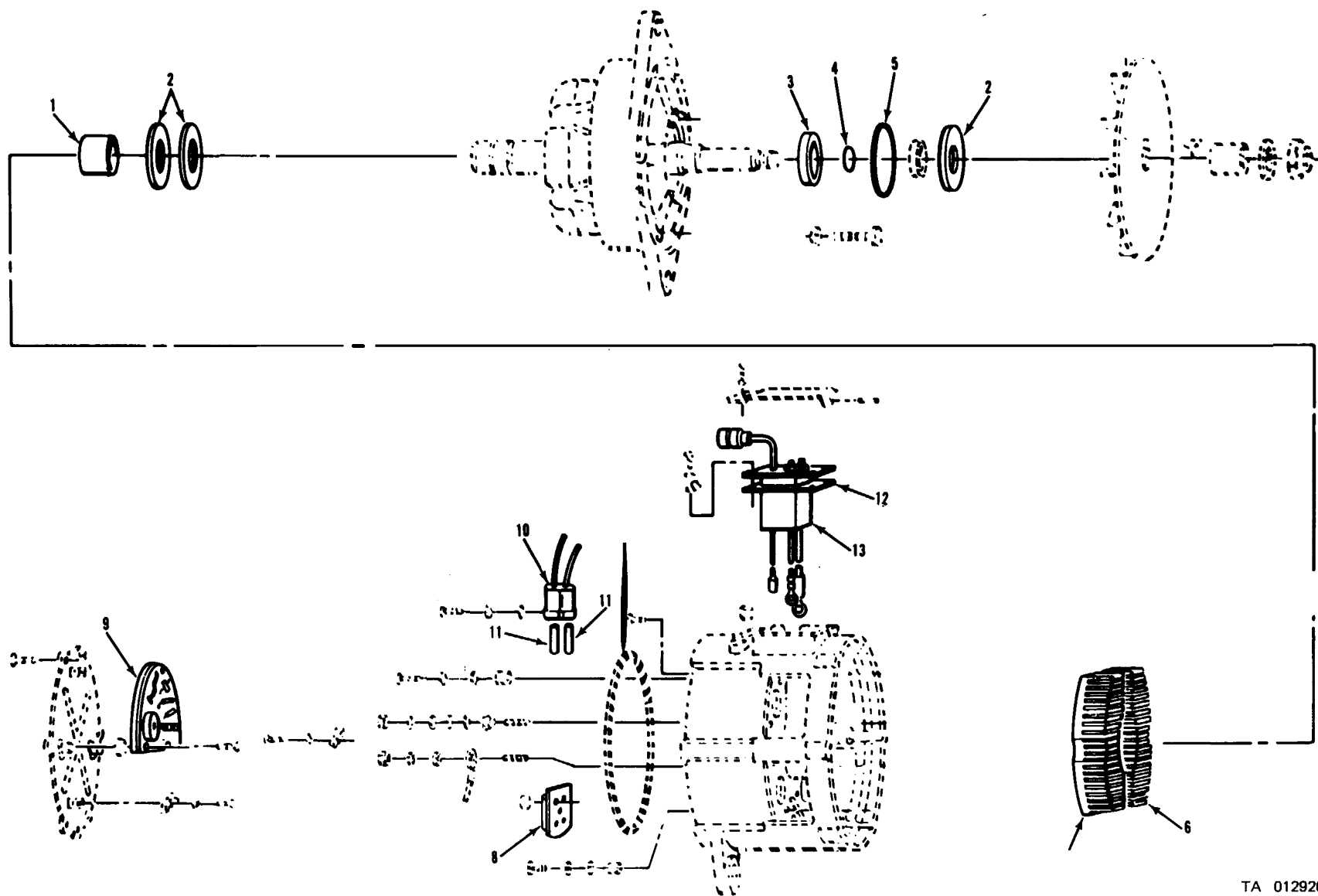
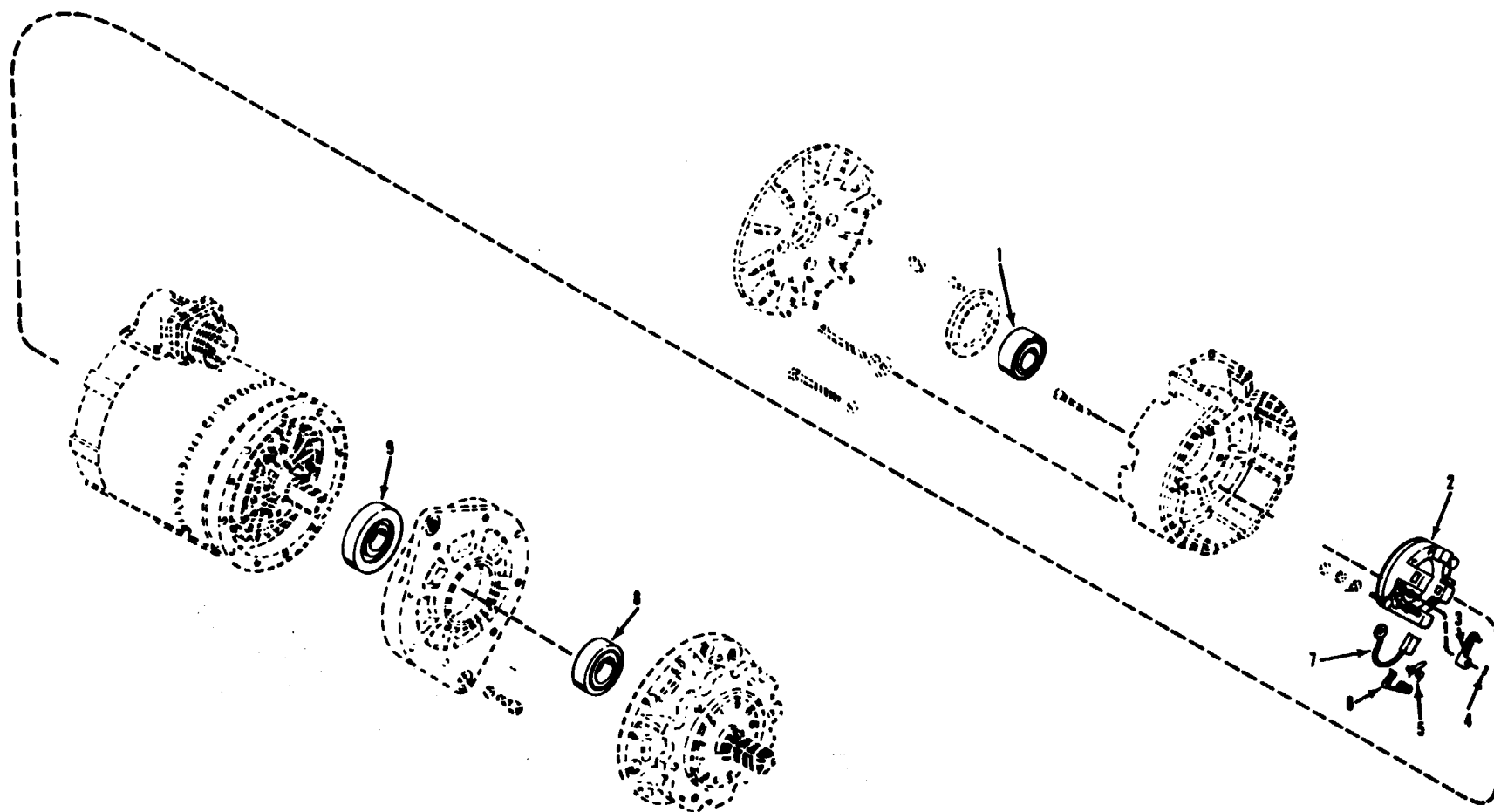

Figure 3. Generator, AD

TA 012920



TA 012921

Figure 4. Generator, Models 5504AA, 5504AB and 5300GP

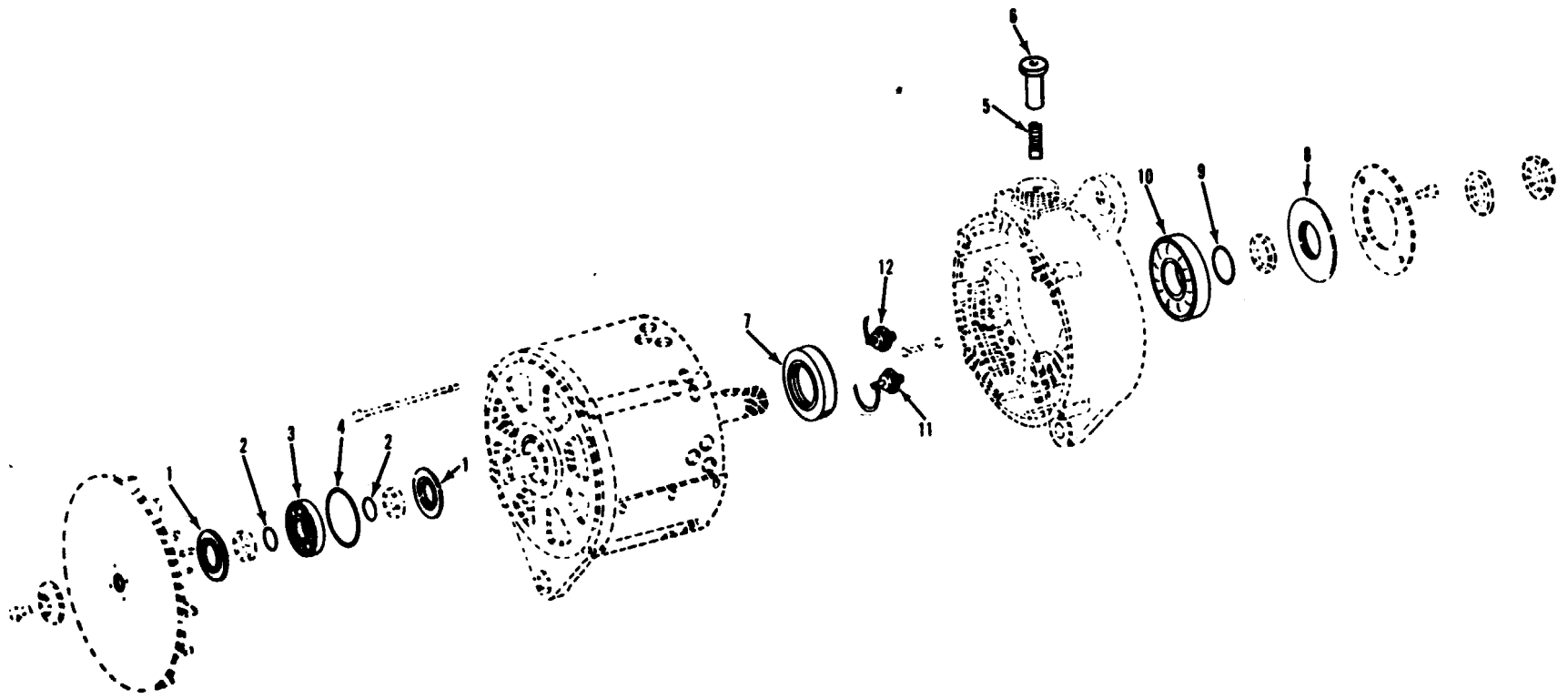

TA 012922

Figure 5. Generator, Model 2184AC

SECTION II. REPAIR PARTS LIST

(1) Illustration		(2) SMR code	(3) Federal stock number	(4) Part number	(5) FSCM	(6) Description	Usable on code	(7) UM	(8) QTY inc in unit
(a) Fig. No.	(b) Item No.								
GROUP 06-ELECTRICAL SYSTEM									
1	1	PAFZZ	2920-078-2351	AMA 1004S	19728	0601-GENERATOR,ENGINE ACCESSORY: END COVER AND REGULATOR	A	EA	1
1	2	PAFZZ	5330-078-0304	XA 744AW	19728	PACKING,PREFORMED:	A	EA	1
1	3	PAFZZ	5999-078-2386	AMA 2042S	19728	HEAT SINK,ELECTRICAL--ELECTRONIC COMPONENT.	A	EA	1
1	4	PAFZZ	5999-078-2387	AMA 2046S	19728	HEAT SINK,ELECTRICAL-ELECTRONIC COMPONENT:	A	EA	1
1	5	XAFZZ		AMA 5S	19728	HOUSING,INTERMEDIATE:	A	EA	1
1	6	XAFZZ		AMA 3008	19728	HOUSING,STATOR ASSEMBLY:	A	EA	1
1	7	PAFZZ	5330-078-0265	XA 744AV	19728	PACKING,PREFORMED:	A	EA	1
1	8	PAFZZ	2920-078-2385	AMA 2028S	19728	TERMINAL BOARD ASSEMBLY:	A	EA	1
1	9	KFFZZ		AMA 19S	19728	SPRING SET: (Part of KIT P/N 229)	A	EA	1
1	10	KFZZ		AMA 1012S	19728	BRUCH SET: (Part of KIT P/N 229)	A	EA	1
1		PAFZZ	2920-078-2390	229	19728	PARTS KIT,ENGINE GENERATOR: COMPOSED OF:	A	EA	1
1	9					SPRING SET		EA	1
1	10					BRUSH SET		EA	1
2	1	PAFZZ	5961-478-0751	78163	355109	SEMICONDUCTOR DEVICE:	B	EA	1
2	2	PAFZZ	5961-477-0439	78162	35510	SEMICONDUCTOR DEVICE:	B	EA	1
2	3	PAFZZ	2920-928-6141	60238	35510	CAPACITOR AND LEAD ASSEMBLY:	B	EA	1
2	4	PAFZZ	5330-059-4893	60217	35510	GASKET:	B	EA	1
2	5	PAFZZ	5977-894-0765	60174	35510	HOLDER,BRUSH:	B	EA	1
2	6	PAFZZ	5977-928-6147	11646900	19207	BRUSH,ELECTRICAL CONTACT:	B	EA	2
2	7	PAFZZ	5935-197-4331	60050	35510	CONNECTOR,RECEPTACLE:	B	EA	1
2	8	PAFZZ	5330-788-3618	60020	35510	PACKING,PREFORMED:	B	EA	1
2	9	PAFZZ	2920-928-6144	60177	35510	REGULATOR,ALTERNATOR:	B	EA	1
2	10	PAFZZ	3110-788-3619	60008	35510	BEARING,BALL,ANNULAR:	B	EA	1
2	11	PAFZZ	5330-823-4882	60199	35510	PACKING,PREFORMED:	B	EA	1
2	12	PAFZZ	5910-422-4250	60292	35510	CAPACITOR ASSEMBLY: U/O GENERATOR,SERIAL NO. 35,000 AND UP,ONLY)	B	EA	1
2	13	PAFZZ	5330-823-4919	60186	35510	SEAL,PLAIN ENCASED:	B	EA	1
2	14	PAFZZ	3110-929-8367	60262	35510	BEARING,BALL,ANNULAR:	B	EA	1
2	15	PAFZZ	5330-823-4883	60255	35510	PACKING,PERFORMED:	B	EA	1
3	1	PAFZZ	3110-165-6325	78249	35510	BEARING,ROLLER,NEEDLE:	C	EA	1
3	2	PAFZZ	5330-823-4919	60186	35510	SEAL:	C	EA	3
3	3	PAFZZ	3110-788-3619	60008	35510	BEARING,BALL,ANNULAR:	C	EA	1
3	4	PAFZZ	5330-823-4882	60199	35510	PACKING,PREFORMED:	C	EA	1
3	5	PAFZZ	533-071-8735	78264	35510	PACKING,PREFORMED:	C	EA	1
3	6	PAFZZ	5961-478-0751	78163	35510	SEMICONDUCTOR DEVICE:	C	EA	1
3	7	PAFZZ	5961-477-0439	78162	35510	SEMICONDUCTOR DEVICE:	C	EA	1
3	8	PAFZZ	5910-165-2848	78219	35510	CAPACITOR ASSEMBLY:	C	EA	1
3	9	PAFZZ	2920-116-8399	78214	35510	REGULATOR ASSEMBLY,GENERATOR:	C	EA	1

(1) Illustration		(2) SMR code	(3) Federal stock number	(4) Part number	(5) FSCM	(6) Description	(7) U/M	(8) Qty inc in unit
(a) FIG NO	(b) Item NO							
						0601-GENERATOR, ENGINE ACCESSORY-continued		
3	10	PAFZZ	5977-165-5898	78225	35510	HOLDER,ELECTRICAL CONTACT	C	EA 1
3	11	PAFZZ	5977-928-6147	11646900	19207	BRUSH,ELECTRICAL CONTACT	C	EA 2
3	12	PAFZZ	5330-059-4893	60217	35510	GASKET	C	EA 1
3	13	PAFZZ		78224	35510	CAPACITOR AND LEAD ASSEMBLY:	C	EA 1
4	1	PAFZZ	3110-109-1123	36609	35510	BEARING,BALL,ANNULAR:	D,E,F	EA 1
4	2	PAFZZ	5977-695-6311	8672841	19207	HOLDER ASSEMBLY,ELECTRICAL	D,E,F	EA 1
4	3	XBFZZ		8672719	19207	LEVER,BRUSH:	D,E,F	EA 2
4	4	PAFZZ		01263	35510	PIN,COTTER:	D,E,F	EA 4
4	5	PAFZZ	5360-318-8198	8677114	19207	SPRING,HELICAL,TORSION: (Part of KIT P/N 570339)	D,D,F	EA 4
4	6	PAFZZ	5977-441-9322	31781	35510	LEVER-BRUSH:	D,E,F	EA 2
4	7	PAFZZ	5977-695-9212	8677118	19207	BRUSH,ELECTRICAL CONTACT: (Part of KIT P/N 5703339)	D,E,F	EA 4
4	8	PAFZZ	3110-275-0117	7064924	19207	BEARING,BALL ANNULAR:	F	EA 1
4	9	PAFZZ	3110-109-1157	11689377	19204	BEARING,BALL, ANNULAR:	D,E	EA 1
4		PAFZZ	2920-654-7271	5702339	19207	PARTS KIT,ENGINE GENERATOR:	D,E,F	EA 1
4	5					SPRING		EA 4
4	7					BRUSH		EA 4
5	1	KFFZZ		11646898	19207	WASHER,NONMETALLIC: (Part of KIT P/N 5703776)	G	EA 2
5	2	KFFZZ		11646803	19207	PACKING,PREFORMED: (Part of KIT P/N 5703776)	G	EA 2
5	3	PAFZZ		11646902	19207	BEARING,BALL,ANNULAR:	G	EA 1
5	4	PAFZZ	5330-019-0635	MS9068-030	96906	PACKING,PREFORMED: (Part of KIT P/N 5703776)	G	EA 1
5	5	KFFZZ		11646896	19207	WASHER,NONMETALLIC: (Part of KIT P/N 5703776)	G	EA 1
5	6	KFFZZ		11646895	19207	RECTIFIER AND LEAD ASSEMBLY: (Part of KIT P/N 5703776)	G	EA 3
5	7	PAFZZ	2920-900-8163	10947913	19207	HOLDER AND STUD ASSEMBLY: (Part of KIT P/N 5703776)	G	EA 2
5	8	PAFZZ	5977-928-6147	11646900	19207	BRUSH,ELECTRICAL CONTACT (Part of KIT P/N 5703776)	G	EA 2
5	9	PAFZZ		11646897	19207	BEARING,BALL,ANNULAR:	G	EA 1
5	10	KFFZZ		11646804	19207	PACKING,PREFORMED: (Part of KIT P/N 5703776)	G	EA 1
5	11	KFFZZ		11646899	19207	WASHER,NONMETALLIC: (Part of KIT P/N 5703776)	G	EA 1
5	12	KFFZZ		11646901	19207	RECTIFIER AND LEAD ASSEMBLY: (Part of KIT P/N 5703776)	G	EA 3
5		PAFZZ	2920-472-1723	57003776	19207	PARTS KIT,ENGINE GENERATOR:	G	EA V
5	2					WASHER		EA 2
5	4					PACKING		EA 2
5	5					PACKING		EA 1
5	6					WASHER		EA 1
5	7					RECTIFIER AND LEAD ASSEMBLY		EA 3
5	8					HOLDER AND STUD ASSEMBLY		EA 2
5	10					BRUSH		EA 2
5	11					PACKING		EA 1
5	12					WASHER		EA 1
5		PEFFF	5120-076-3286	60266	35510	RECTIFIER AND LEAD ASSEMBLY		EA 3
						REPLACER,OIL SEAL:	A,B	EA 1

SECTION III. FEDERAL STOCK NUMBER AND PART NUMBER INDEX

FSN	Fig. No.	Item No.	FSN	Fig. No.	Item No.
2920-078-2351	1	1	5330-823-4882	2	11
2920-078-2385	1	8		3	4
2920-078-2390	1	KIT	5330-823-4883	2	15
2920-116-8399	3	9	5330-823-4919	2	13
2920-472-1723	5	KIT		3	2
2920-654-7271	4	KIT	5360-318-8198	4	5
2920-900-8163	5	7	5910-165-2848	3	8
2920-928-6141	2	3	5910-422-4250	2	12
2920-928-6144	2	9	5935-197-4331	2	7
3110-109-1123	4	1	5961-477-0439	2	2
3110-109-1157	4	9		3	7
3110-165-6525	3	1	5961-478-0751	2	1
3110-275-0117	4	8		3	6
3110-788-3619	2	10	5977-165-5898	3	10
	3	3	5977-441-9322	4	6
3110-929-8367	2	14	5977-695-7311	4	2
5330-019-0635	5	4	5977-695-9212	4	7
5330-059-4893	2	4	5977-894-0765	2	5
	3	12	5977-982-6147	3	6
5330-071-8735	3	5		3	11
5330-078-0265	1	7		5	8
5330-078-0304	1	2	5999-078-2386	1	3
5330-788-3618	2	8	5999-078-2387	1	4

<i>Part No.</i>	<i>Mfg Code</i>	<i>Fig. No.</i>	<i>Item No.</i>	<i>Part No.</i>	<i>Mfg Code</i>	<i>Fig No.</i>	<i>Item No.</i>
AMA1004S	19728	1	1	60008	35510	2	10
AMA1012S	19728	1	10			3	3
AMA19S	19728	1	9	60020	35510	2	8
AMA2028S	19728	1	8	55050	35510	2	7
AMA2042S	19728	1	3	60174	35510	2	5
AMA2046S	19728	1	4	60177	35510	2	9
AMA3008	19728	1	6	60186	35510	2	13
AMASS	19728	1	5			3	2
MS9068-030	96906	5	4	60199	35519	2	11
XA744AV	19278	1	7			3	4
XA744AW	19278	1	2	60217	35519	2	4
01263	35519	4	4			3	12
10949713	19207	5	7	60238	35510	2	3
11646803	19207	5	2	60255	35510	2	15
11646804	19207	5	10	60262	35510	2	14
11646895	19207	5	6	60292	35510	2	12
11646896	19207	5	5	7065924	19207	4	8
11646897	19207	5	9	78162	35510	2	2
11646898	19207	5	1			3	7
11646899	19207	5	11	78163	35510	2	1
11645900	19207	2	6			3	6
		3	11	78214	35510	3	9
		5	8	78219	35510	3	8
11646901	19207	5	12	78224	35510	3	13
11646902	19207	5	3	78225	35519	3	10
11689377	19207	4	9	78249	35510	3	1
229	19728	1	KIT	78264	35519	3	5
31781	35510	4	6	8672719	19207	4	3
36609	35510	4	1	8672841	19207	4	2
5702339	19207	4	KIT	8677114	19207	4	5
5793776	19207	5	KIT	8677118	19207	4	7

By Order of the Secretary of the Army:

Official:

VERNE L. BOWERS

Major General, United States Army

The Adjutant General

CREIGHTON W. ABRAMS
General, United States Army
Chief of Staff

Distribution:

To be distributed in accordance with DA Form 12-38 (qty rqr block No. 251), Direct and General Support maintenance requirements for Truck; Utility 1/4-Ton M151.

* U.S. GOVERNMENT PRINTING OFFICE: 1974-650000/5003

RECOMMENDED CHANGES TO EQUIPMENT TECHNICAL PUBLICATIONS



THEN...JOT DOWN THE
DOPE ABOUT IT ON THIS FORM.
CAREFULLY TEAR IT OUT, FOLD IT
AND DROP IT IN THE MAIL.

SOMETHING WRONG WITH PUBLICATION

FROM: (PRINT YOUR UNIT'S COMPLETE ADDRESS)

DATE SENT

PUBLICATION NUMBER

PUBLICATION DATE

PUBLICATION TITLE

BE EXACT PIN-POINT WHERE IT IS

PAGE
NO.

PARA-
GRAPH

FIGURE
NO.

TABLE
NO.

IN THIS SPACE, TELL WHAT IS WRONG
AND WHAT SHOULD BE DONE ABOUT IT.

TEAR ALONG PERFORATED LINE

PRINTED NAME, GRADE OR TITLE AND TELEPHONE NUMBER

SIGN HERE

